





04	The Vision
06	The Masterplan
09	Grand Polo Estate
14	The Stables
18	The Clubhouse
24	The Landscapes
30	Regal Residences
35	Endnote



# An Unprecedented *Vision*

A manifestation of luxurious living, blending the heritage of captivating equestrian experiences with seamless landscapes exuding modernity. An architectural style which is a fusion of form and function, entirely unparalleled. A lifestyle that offers an opportunity to be one with nature, every day.

*Welcome to*  
Grand Polo Club & Resort  
by Emaar.



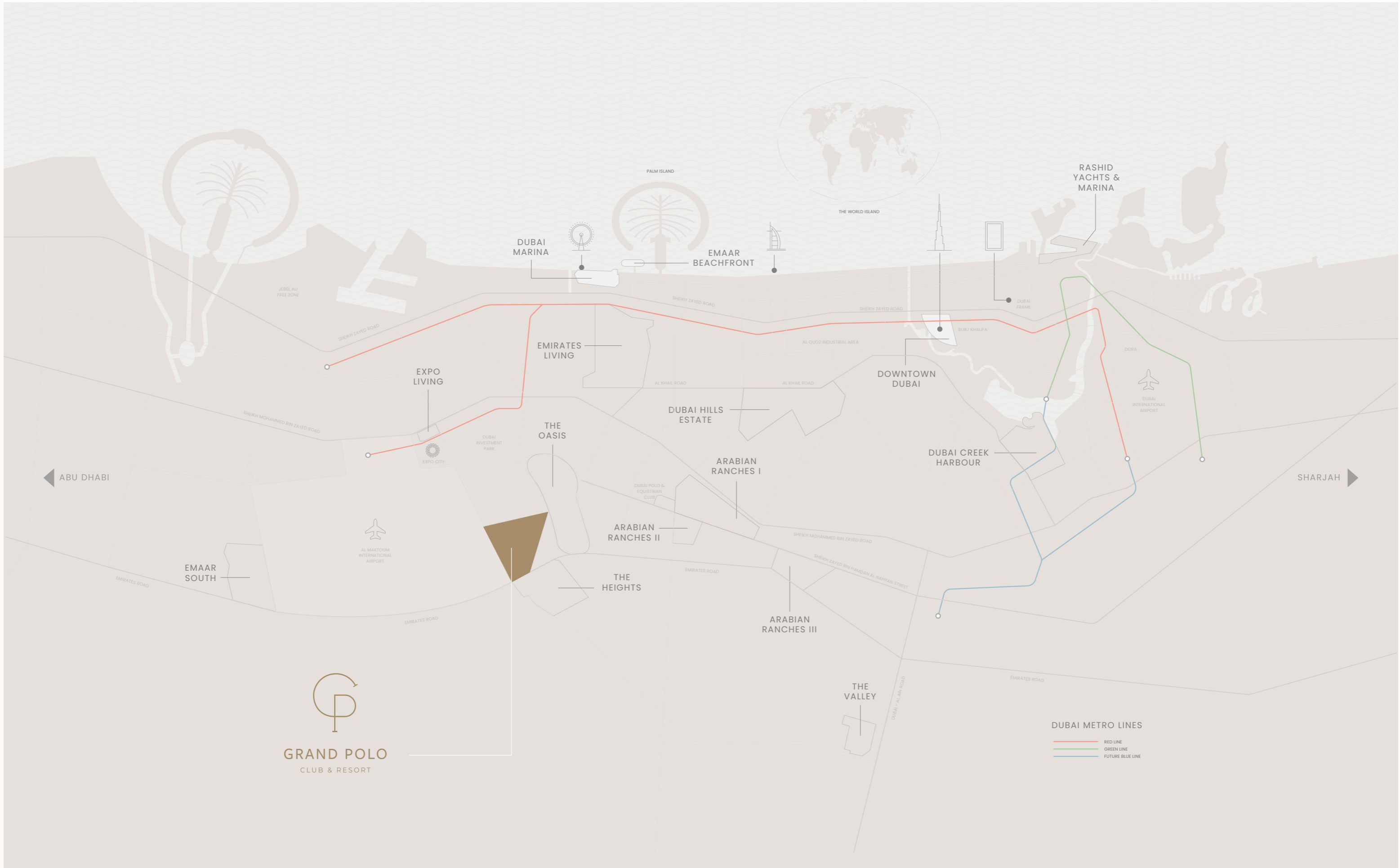

  
**GRAND POLO**  
 CLUB & RESORT

**DUBAI METRO LINES**  
 RED LINE  
 GREEN LINE  
 FUTURE BLUE LINE





## *A Balanced* Masterpiece

Grand Polo Club & Resort is a masterplan which is built to strike fine balance between lifestyle principles of leisure, nature, connectivity, wellness and recreation. Whilst having the equestrian prestige at its heart, the green spaces loop-around and branch-out across the masterplan, connecting the residences thereby fostering a sense of community and belonging.

# Grand Polo Club & Resort *Masterplan*

Masterplan Total Area	5,54 million SqM
Total Open Space	1,59 million SqM
Total Polo Field & Stables Expans	340,000 SqM
Clubhouse GFA	5,600 SqM
Total Mix Use GFA	1,56 million SqM
Total Residential Clusters	22
Total Residences	5,599
Estimated Resident Population	24,524







Where Luxury  
Meets *Equestrian*  
Heritage

A space crafted to harness the spirit and speed of the horses. Seamless landscapes envisioned to offer a contemporary take on the classic Polo grounds. Inspired by natural elements and textures of soil – these grounds define the monumentality of the vision spanning across 340,000 SqM.



*Geometric Control* ————— For the true connoisseurs  
of architecture, Grand Polo Estate will be a sight to behold. As geometric control is masterfully integrated  
within horizontal and vertical expanses of the venue, it weaves a visual narrative of endless panorama  
of greens and infinite blue skies.



## *The Green Core*

By using landscape berms and expansive lawns, Grand Polo Estate is created for a harmonious environment that emphasizes on the beauty of the exclusive equestrian experiences it has to offer. Situated in the heart of the masterplan, it not only enhances the aesthetic appeal but also promotes a sense of community and connection to nature.



## Homage To *Heritage*

This Clubhouse is a fusion of cultural heritage with contemporary design principles emphasizing on sustainability, honouring the past and addressing modern needs.

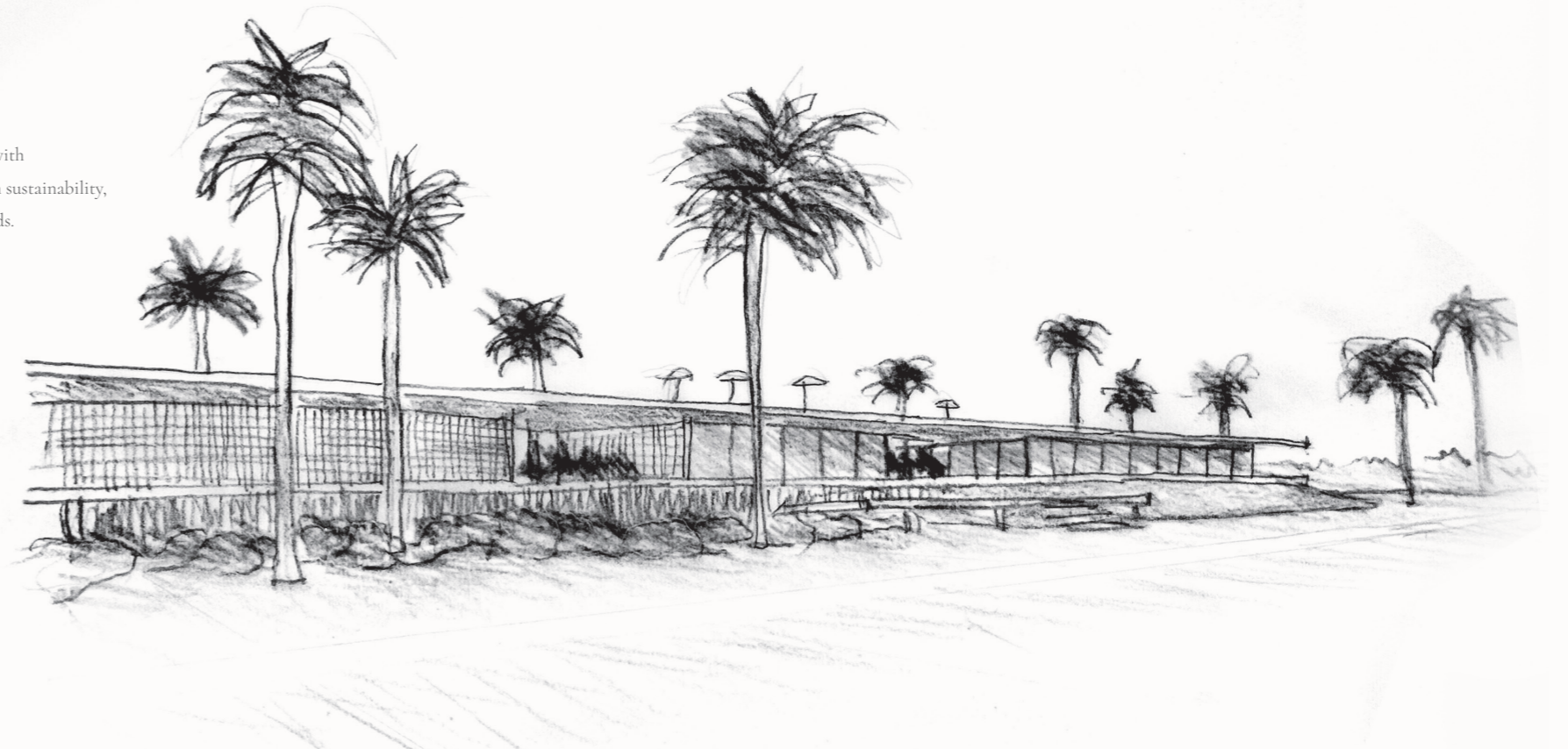

*Modern Marvel* ————— Nestled at the heart of the equestrian center and surrounded by exclusive villas, the Clubhouse is designed as a modern architectural marvel that pays homage to the cultural and historical essence of the Arab region. This structure features a dynamic and airy design, reflecting the vibrant spirit of the Polo sport.







## Sophisticated Symbolism

The design draws inspiration from the symbolic value of the horseshoe, using its shape to breathe life into these unique breeze blocks. This distinctive architectural element not only reinforces the identity of the Clubhouse but also beautifully interacts with light and shadow, creating dynamic patterns throughout.



## Echoes of Elegance

A fundamental element of the Clubhouse architecture is the custom-made clay breeze blocks which stand out distinctively in the design. Inspired by the local history and traditions, these breeze blocks echo the elegance of traditional Islamic motifs further embedding cultural identity into the design.

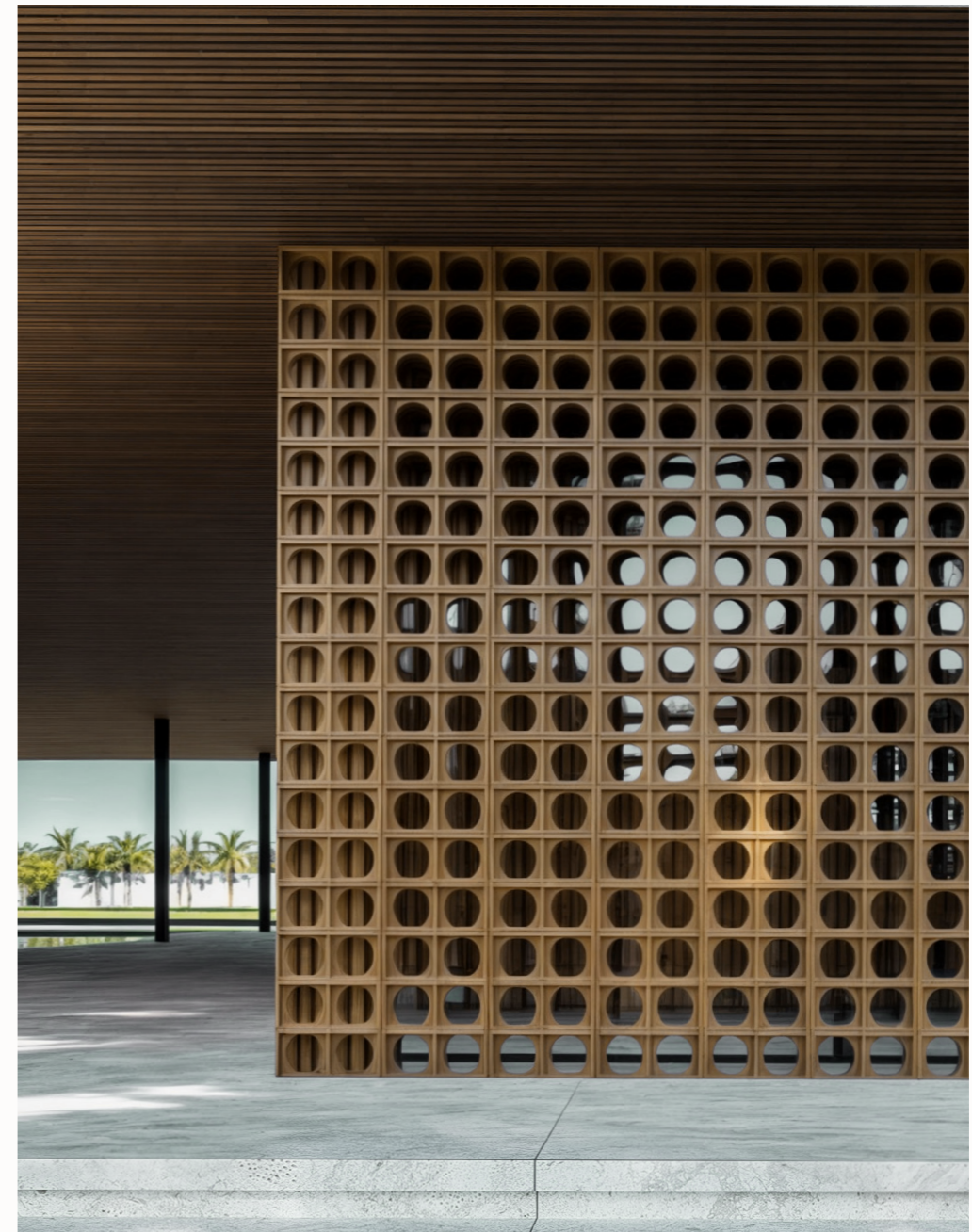
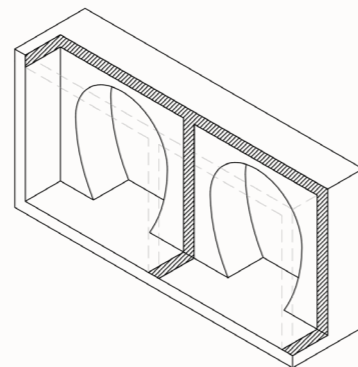
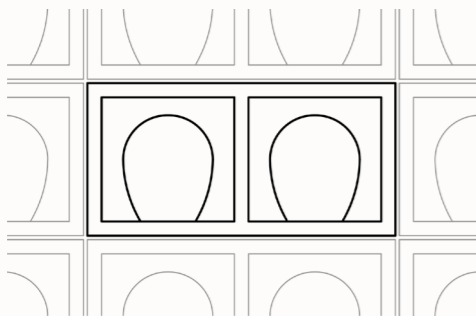



The Most  
*Sought-After Scene*

The elongated, single-storey Clubhouse boasts panoramic views of the Polo Fields and includes a spacious covered terrace for spectators of jumping events, complemented by natural grandstands for various activities. It serves as a central hub, encouraging members to engage in diverse equestrian experiences.





## Experience *The Exceptional*

While Polo serves as the primary focus, Grand Polo Estate also incorporates high-quality jumping arenas, dressage facilities, and a magnificent riding school.



Featuring three polo fields, three jumping arenas, paddocks, a vereo track, elegantly curated horse stables, viewing decks and a social tack lounge – this remarkable icon has designed to have all the elements strategically placed to enhance the experience of both equestrians and spectators.

## Crafting *The Icon*

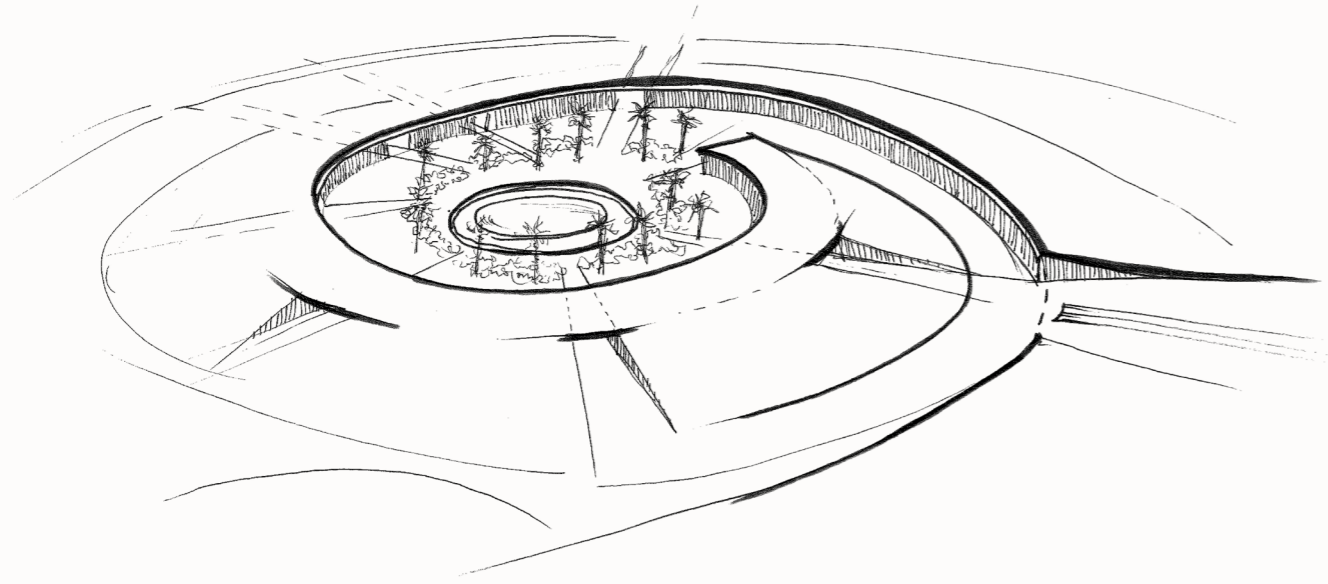

Architectural Sketch

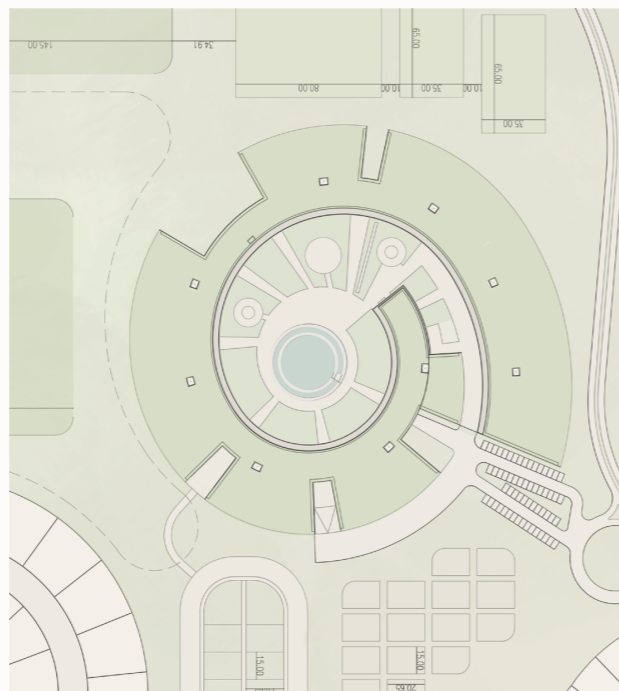

## *Hidden Gem*

An organic, spiralling design that encircles a large, landscaped courtyard. An inviting hidden gem is revealed upon entering the building. This iconic design of the stables is to become a significant global landmark in the equestrian realm





## Thematic *Play*

The landscape defining moves and themes are at the forefront of the unifying vision of Grand Polo Stables.

Integrating circular elements to emphasize on expansiveness, to frame important landscape moments and incorporating water features to serve a playful scenery.

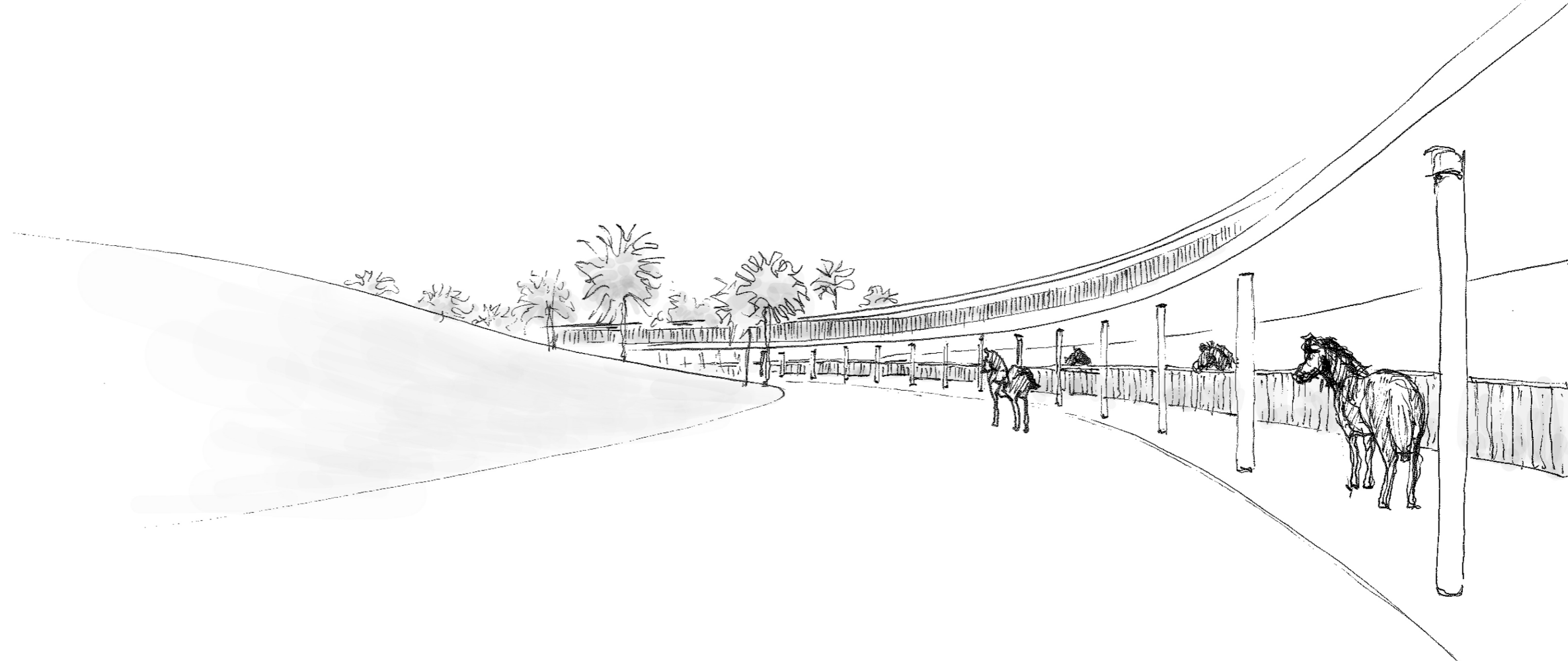



## Landscape Narrative

The open space

strategy for the Grand Polo Club & Resort is designed to feel like a continuous landscape that varies in scale and character. It is set to be a narrative of an equestrian journey that traverses through a multi-sensory landscape, creating a surprise at every turn and creating an everlasting fragment of memory.

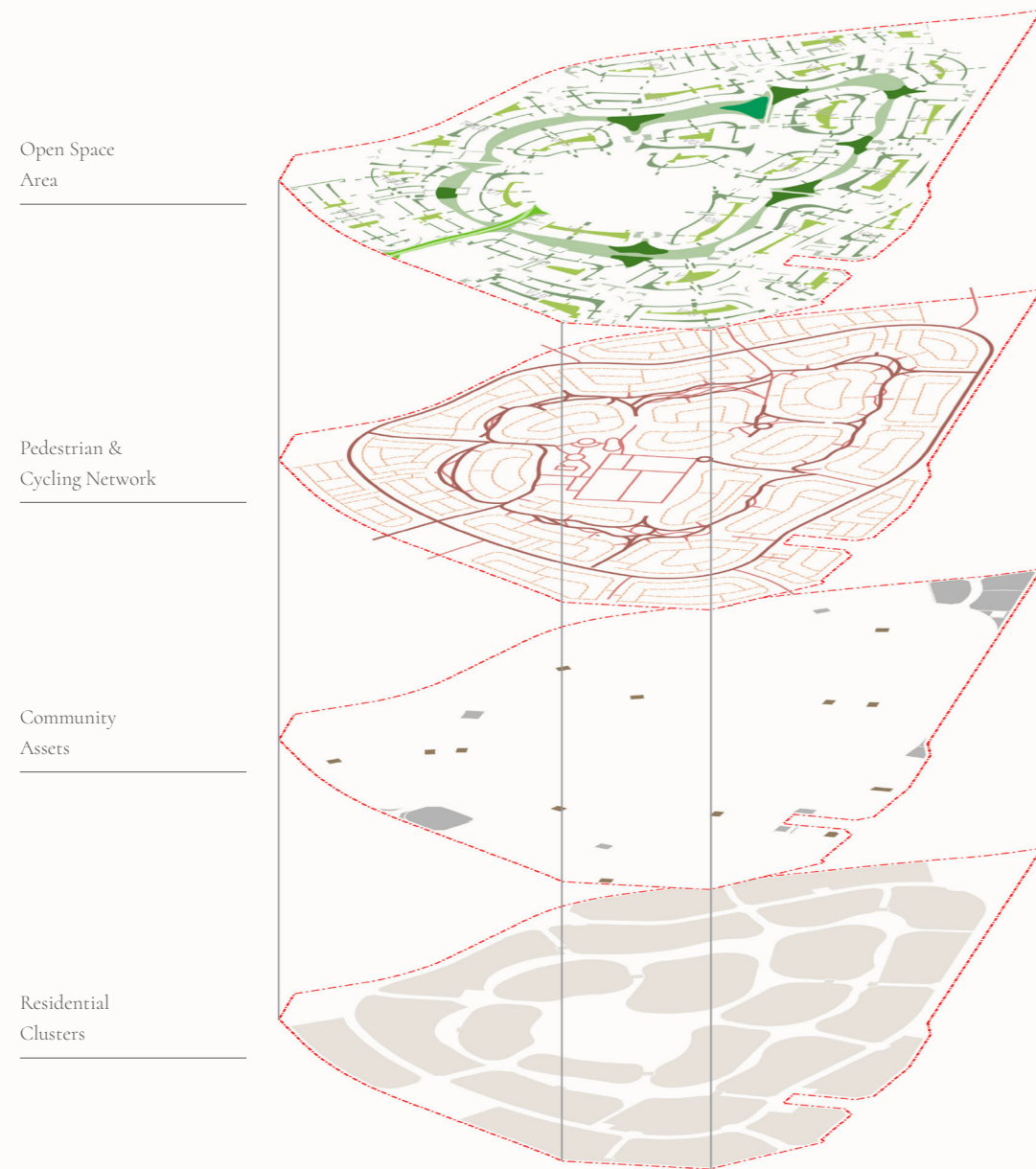

## Designing Natural *Dreamscapes*

While the Grand Polo Estate boasts orthogonal forms and structural planting to highlight grandeur, around a meandering landscape, the Countryside Meadows applies an organic design language with mosaic pattern planting. The Outer Pastures feature an inspiring sequence of natural promenades and intimate courtyards with low-clustered plantings which aims to fill the residents' every day with beauty.



**Connections** — Organizing key character landscapes into three concentric radial patterns has resulted in a masterplan which conveniently connects the heart of this development to all its homes whilst keeping nature in focus.

A Vision of *Grandeur*

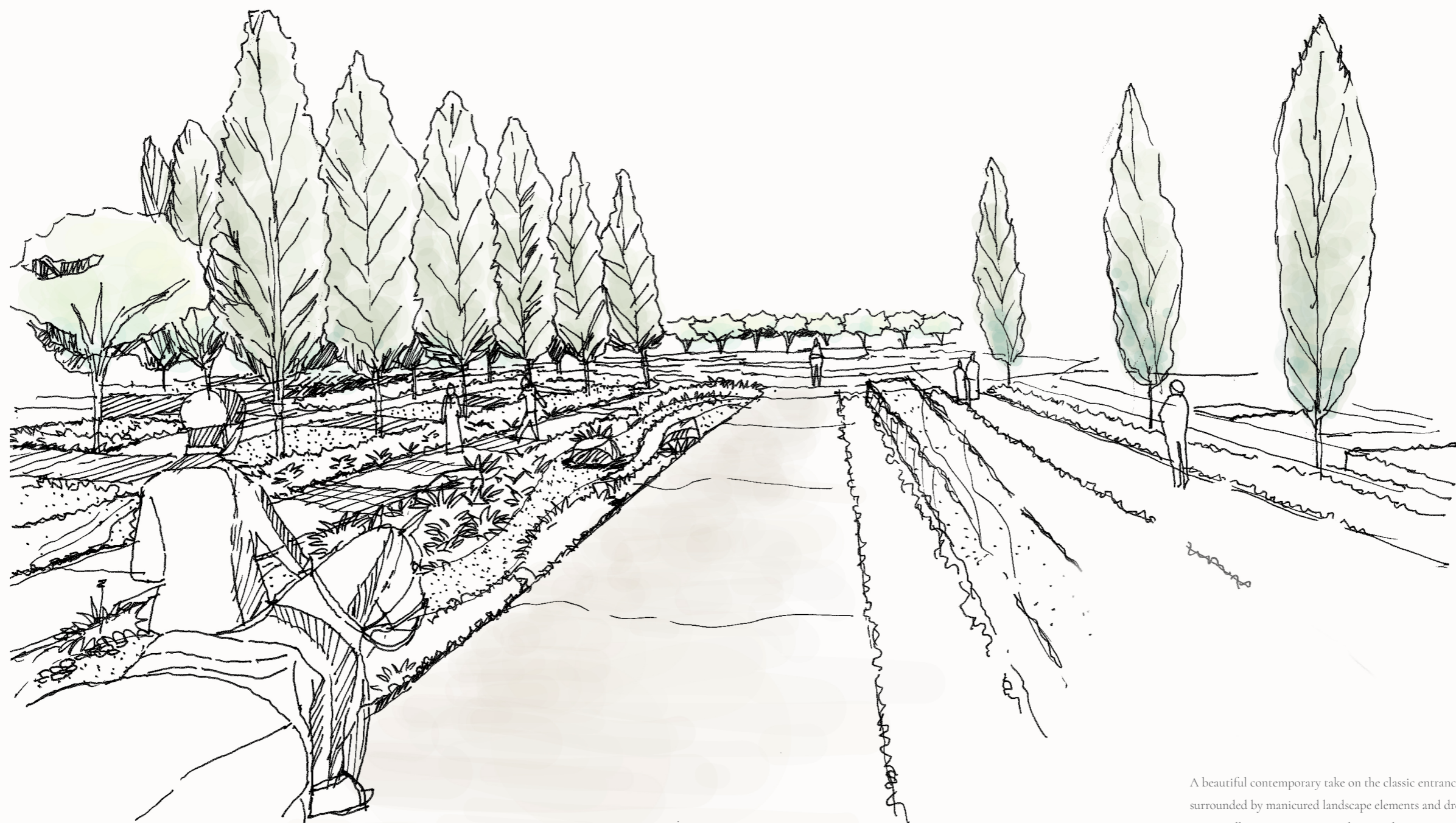

A beautiful contemporary take on the classic entrances to fields, surrounded by manicured landscape elements and dream-like outdoors. A compelling invitation to stride towards experiencing the elegance of captivating landscapes.



# Unforgettable *Landscapes*

Building on the key characteristics of the open spaces, the landscape design methodically examines the journeys of three key user groups: families, Polo enthusiasts, and sport enthusiasts. The spatial design of the open areas is intricately tailored to accommodate and enrich their experiences.



A Welcoming Sight,  
*Leaving Impressions* that Last Forever

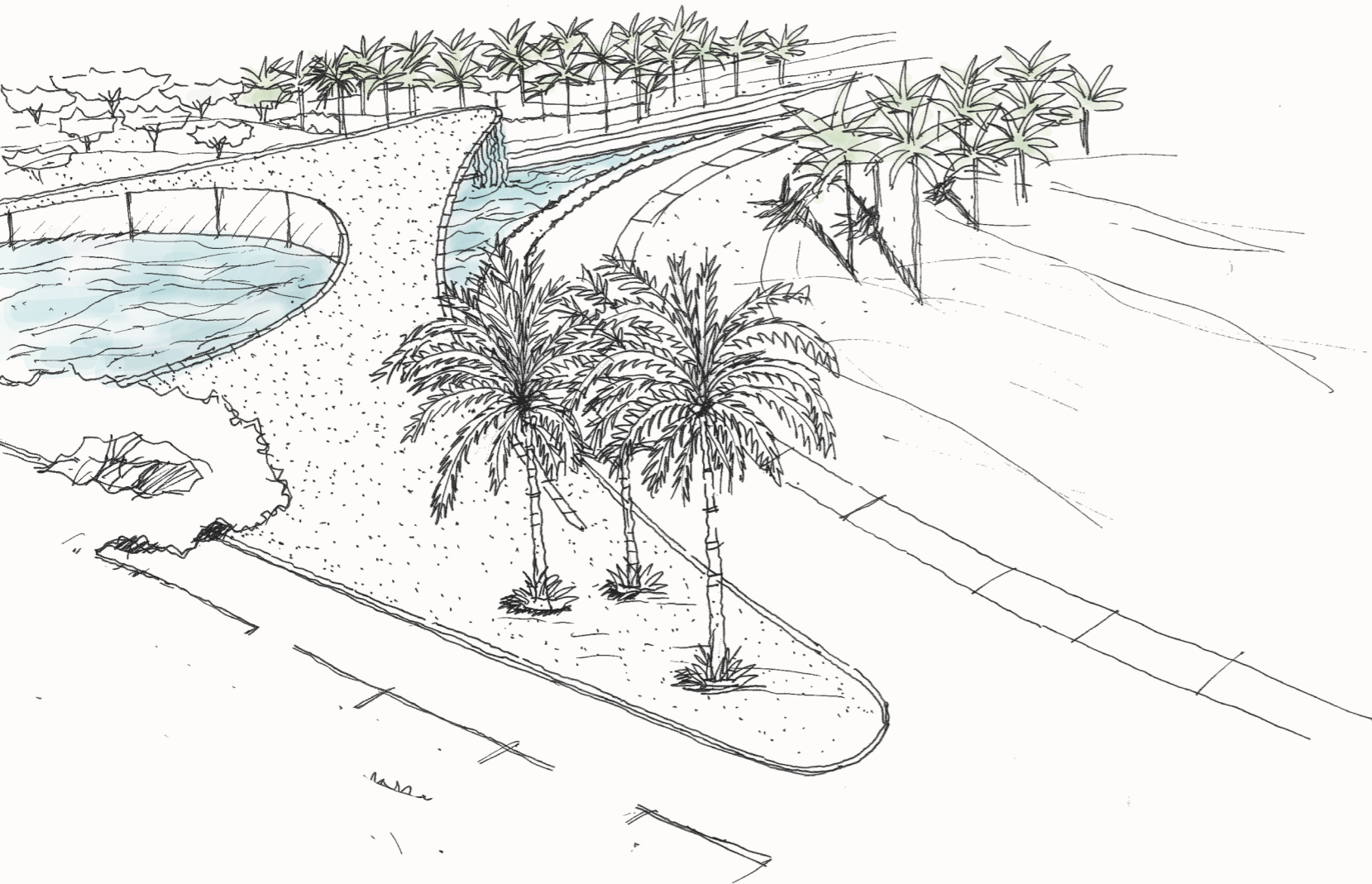

*The Entryway* ————— Following the  
morphology of the design for the Grand Polo Club Stables and echoing the undulating  
landscapes of the open space, *The Entryway* moment is crafted to assure continuity of  
design language throughout the resident's journey home.





## *Exclusive* Living

The design inspiration is invariably applied to the residences of Grand Polo Club & Resort. These exclusive homes are crafted with high emphasis on clean horizontal and vertical lines to exude grandeur and expansiveness.

## Built for *Families*

The core nature of the masterplan design principles is combined with instances of unobstructed views of the green core or countryside meadows, promising to offer a vibrant canvas for an exceptional equestrian lifestyle.





# An Unparalleled Vision of *Equestrian Lifestyle* Awaits

A regal home where the finest of inspired architecture, panoramas and experiences come together. A lifestyle dipped in ultimate opulence where every day unfolds like a poetic narrative. A community which offers a sanctuary of solitude while keeping connections and conversations, still close to home and heart. This is a new chapter of luxury living made for the ones who appreciate the intricate beauty of details.







